

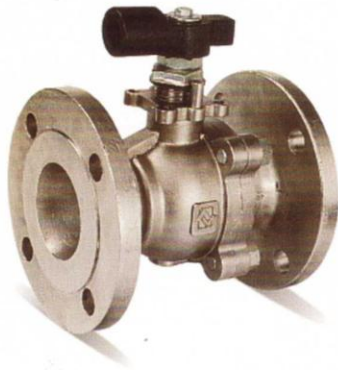

Ball Valves Series V3F

Class 300, Regular / Full port, Flanged End, Floating design



2-PIECE BALL VALVES/2-WAY.

- Maintenance free live loaded double sealing stem packing ensures high cycles life and positive sealing.
- ISO 5211 Mounting Pad Allows for mounting of actuator.
- Blow-Out Proof Stem.

These High performance floating design Ball Valves have the following advantages:

Superior sealing : Seat to ball sealing is further improved by allowing both the ball and seat to move. This provides a leak tight seal even at low pressures. The floating ball increases compression against the seat as system pressure increase.

Self Cleaning : The floating design allows entrapped fluid to be continually drain from the valve cavity. The internal washing action keeps the seats free of contaminated ingredients and guarantees superior valve performance.

Self adjusting : The seat and ball interface allows the seat to expand and contract in order to maintain proper ball contact at all times thus resulting in self adjustment.

Smooth operation & reduced wear : There is reduced friction on the seat when it comes in contact with the ball during opening and closing and thus enhances the ball valve's life.

Conformity to codes & standards:

General design & manufacturing.	:	EN17292 API-6D.
Valve dimensions.	:	ANSI B 16.10 / B 16.5.
Valve inspection & testing	:	EN 12266
		Hydro shell : 77 kg/sq.cm
		Seat test : 51 kg/sq.cm
		Air seat : 7kg/sq.cm
Special features	:	Fire safe to API-607.
		Metal to Metal Seats

Technical specification :

Valve type	:	Floating design ball valve.
Body type	:	2 pc.
Seat Type	:	Soft/Metal
End connection	:	Flanged.
Size range	:	15 NB to 300 NB for reduced port/full port.
Pressure rating	:	Class 300.
seat leakage,	:	Class VI - Soft Seat, Class V-Metal Seats
Operation	:	Hand lever / Gear / Actuator (Electrical / Pneumatic).

CLASS 300 FLOATING DESIGN BALL VALVE

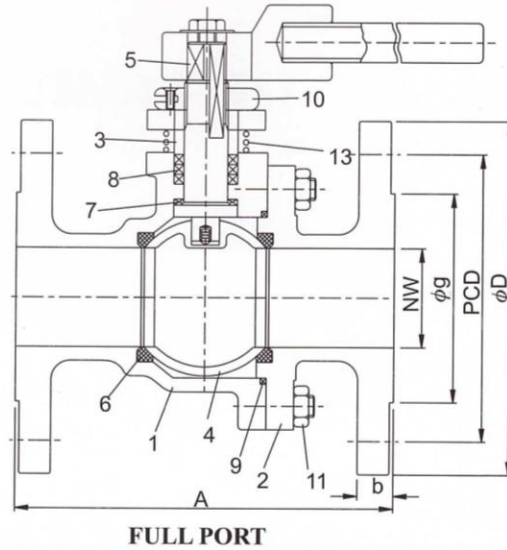
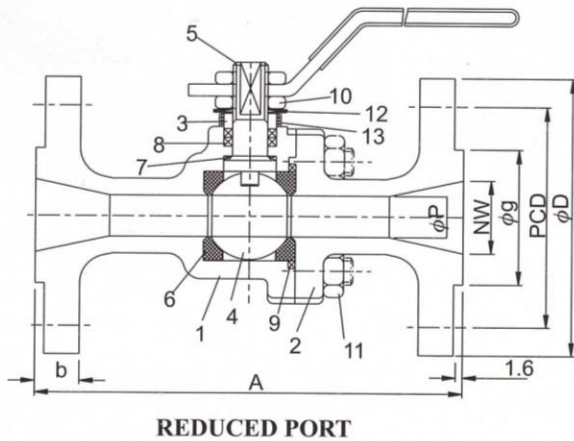

Dimensional Data In mm

Size	A	NW	φP	φD	b	φg	PCD	Holeφ	No. of Holes
15	140	13	9.5	95	14.5	35	66.7	16	4
20	152	19	13	117	16	43	82.5	20	4
25	165	25	19	124	17.5	51	89	20	4
32	178	32	25	133	19.5	64	98.4	20	4
40	190	38	32	156	22	73	114.3	23	4
50	216	50	38	165	22.5	92	127	20	8
65	241	65	50	191	25.5	105	149.2	23	8
80	283	76	58	210	29	127	168.3	23	8
100	305	98	76	254	32	157	200	23	8
150	403	148	98	318	37	216	269.9	23	12
200*	419	198	144	381	41.5	270	330.2	26	12
250*	457	254	187	445	48	324	387.3	29	16
300*	502	305	228	520	51	381	450.8	32	16

Gear Operated

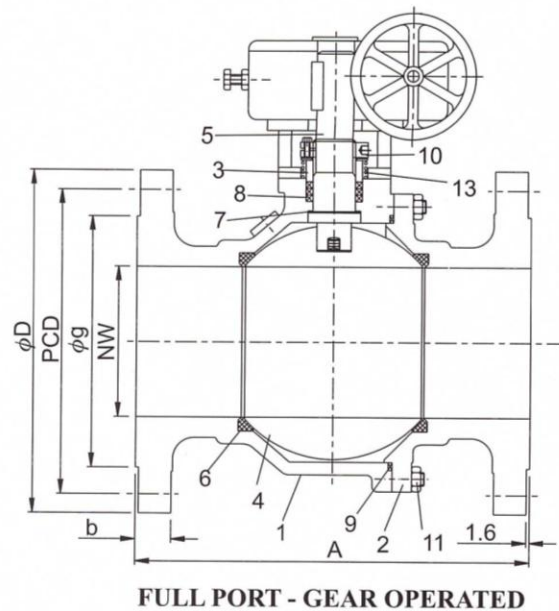

Standard material of construction :

- | | |
|---|--|
| <p>1. Body : A105, WCB, CF8, CF8M, CF3, CF3M, F304, F316, CN7M, WCC/CCB/Duplex SS</p> <p>2. Pipe end : A105, WCB, CF8, CF8M, CF3, CF3M, F304, F316, CN7M, WCC/CCB/Duplex SS</p> <p>3. Gland : ANSI410, 304, 316, 316L, MONEL, ALLOY20, HAST-B, C, WCC/CCB/Duplex SS</p> <p>4. Ball : ANSI410, 304, 316, 316L, MONEL, ALLOY20, HAST-B, C, Duplex SS</p> <p>5. Stem : ANSI410, 304, 316, 316L, MONEL, ALLOY20, HAST-B, C.</p> | <p>6. Seat : PTFE, GFT, CFT / Metal to Metal / Delrin, Nylon.</p> <p>7. Stem seal : GFT</p> <p>8. Gland Packing : PTFE, Grafoil.</p> <p>9. Body seal : PTFE, Grafoil.</p> <p>10. Gland nut : Carbon steel.</p> <p>11. Body stud/nut : B7/2H, B8/B8M.</p> <p>12. Belleville spring: Spring steel</p> <p>13. Antistatic spring: SS 304</p> |
|---|--|



Ball Valves

Salient design features and benefits of our range .

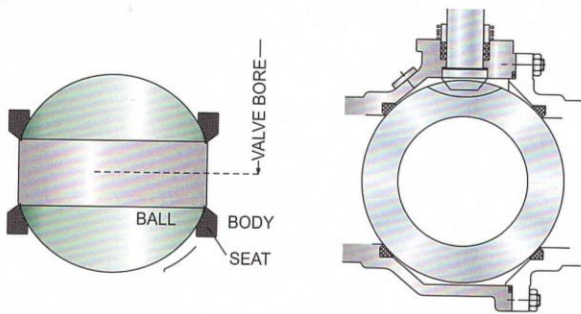

Trunion Mounted design

Trunion mounted design offers precise locational accuracy for the ball within the upstream and downstream seat, which ensures leaktight sealing with lower operative torques. The sealing takes place by allowing the seats to move towards the ball. This design ball valves can hold very high pressures.

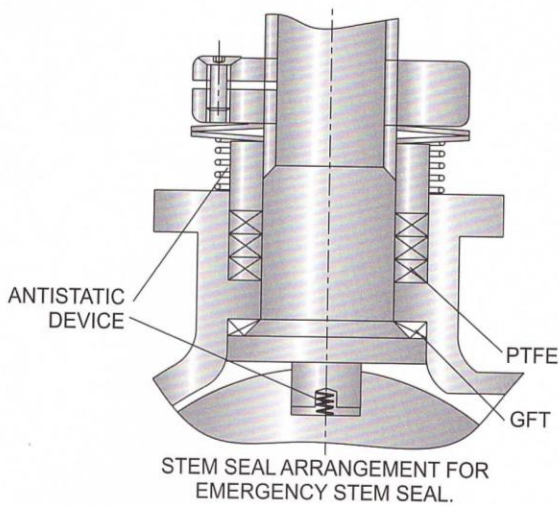

Floating design

A floating ball design offers efficient sealing with simple construction. As the name indicates, the ball has some freedom to move along the axis of the pipeline, which offers efficient downstream sealing. When line pressure is applied to the closed ball, it moves slightly (or floats) downstream to maintain contact with the downstream seat where primary sealing occurs. A quarter turn motion from full open to full close ensures quick open-close action, an inherent advantage for automatic remote control application. Floating ball valve offers effective bidirectional sealing.

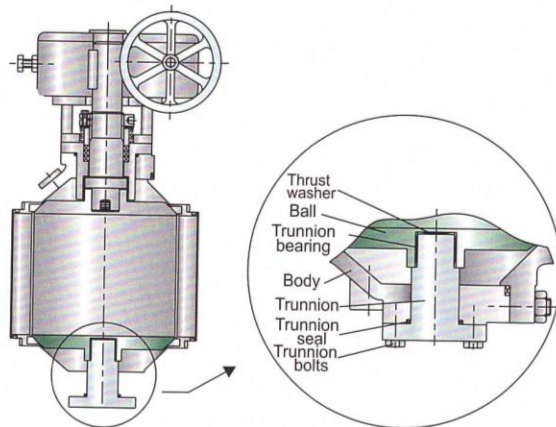

Anti static design feature

Anti-static design feature provided in the valve prevents any accidental fire due to static electric discharge. With the low resistance short circuit path created between the ball and the valve body, any build up of static electric charge on the ball due to constant rubbing within the PTFE seat is prevented. The ball valve is completely conductive between ball and body in which no static electricity may develop - a requirement essential to the treatment of such low flashing point fluids as gasoline, natural liquefied gas, propane gas etc.

Fire-safe

Valves exposed to the risk of accidental external fire need to have additional secondary metal sealing system to make it fire safe. Special design features are built into the valve to ensure continued sealing performance even after burn out of the soft sealing parts of the valve. A metal seat located on the body comes in direct contact with the ball on burnout of the soft parts ensuring continued sealing. Full range approved as per latest edition

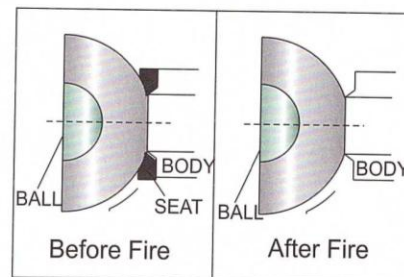

Valve in Closed condition.

Blow out proof and Self-compensating stem

IV Ball valves have safe blow out proof stem assembly, which eliminates the possibilities of hazards. With GFT thrust washer the stem is inserted through the valve body cavity and rests against a shoulder machined in the valve body. PTFE / Graphoil gland packings above the shoulder are held in place by a gland which is machined taper to give sealing between stem and packing.

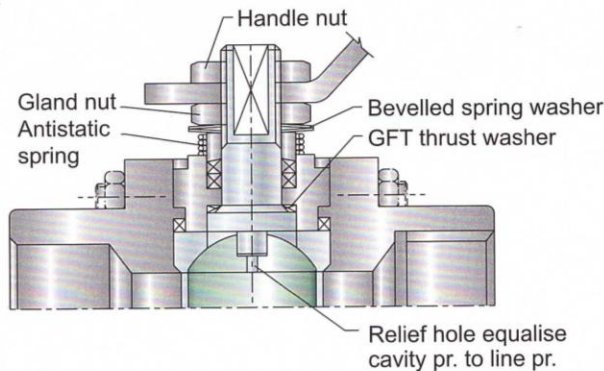

Block and bleed

This is a function for providing seal of fluids by upstream and downstream seats with the valve in close position and for draining the fluids accumulated in the body cavity. The benefits are:

- Leaks and damage to the seats are checked in advance
- Contamination caused during changing fluid types is minimized.
- Parts of the gland seal can be changed under pressure.

Metal seated ball valve

The metal seated ball valves are available in all ranges. Its quality starts with the sphericity of the ball and the surface finish. The ball is of mirror quality finish. This provides outstanding smoothness and roundness, resulting in a prime contribution to low torque and reduced leakage up to class V. The metal seated ball valves typically can be used for higher temperature ranges & abrasive service.

Key Lock

Especially when installed outdoors, to prevent the valve from wrong operation, it is lockable with a pad lock at two points fully closed or fully open positions. In other words, an operation of the valve is limited to protect it against the possibilities that an outsider may accidentally operate the lever or the valve may be opened or closed due to vibrations, especially when an inflammable petroleum product or chemicals are handled.

Self-compensating stem

Above the gland two Belleville washers (disc springs) and gland nut are provided. The gland nut allows gland-packing adjustment, and disc spring automatically compensates for normal wear as well as seal expansion and contraction from temperature fluctuations. The gland nut is provided below the handle permitting the handle to be removed without disturbing the stem adjustment or causing an unsafe condition.

Pressure relief slots

If the pressure of the fluid inside the valve body cavity exceeds the line pressure due to thermal expansion of the liquids entrapped in the valve body, seats provide automatic pressure relief, without the aid of the safety or vent valve. During closing of the valve, the maximum surge pressure occurs, during which the downstream seat can be forced to intrude into the ball port and valve can become inoperative. The pressure relief slots prevent this potential failure. When pressure causes the upstream seat to move against the ball and the ball moves downstream, the pressure simply leaks in to the ball port through the relief slot.

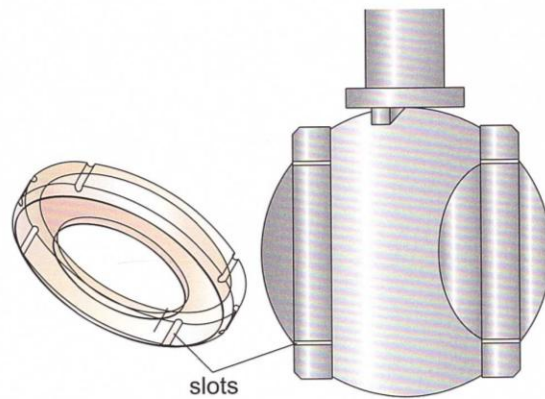

In addition to this we also provide

- Single-seal and double-seal system.
- Sealant injection system can be provided on request.
- Ball valves for cryogenic service, oxygen, chlorine service.
- Jacketed & V-notch ball valves
- Tungsten Carbide & Chromium Carbide coating is available for ball & seat.

The PRESSURE - Temperature rating given below is for reference only.
 For other Temperature / Pressure consult factory
 SERVICE TEMPERATURE

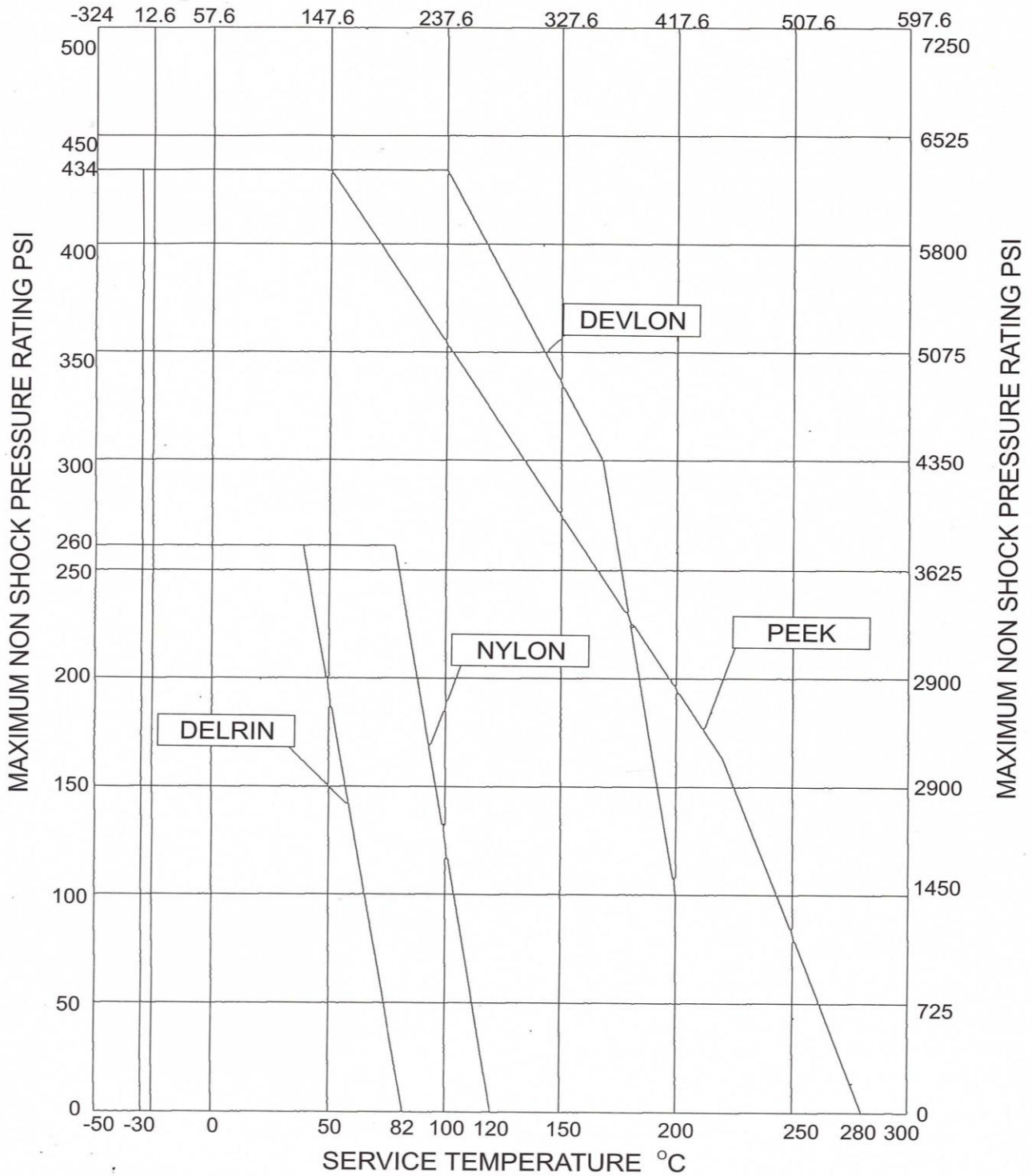

Ball valves Pressure - Temperature Characteristics

Variation of max. non shock pressure w.r.t service temperature.

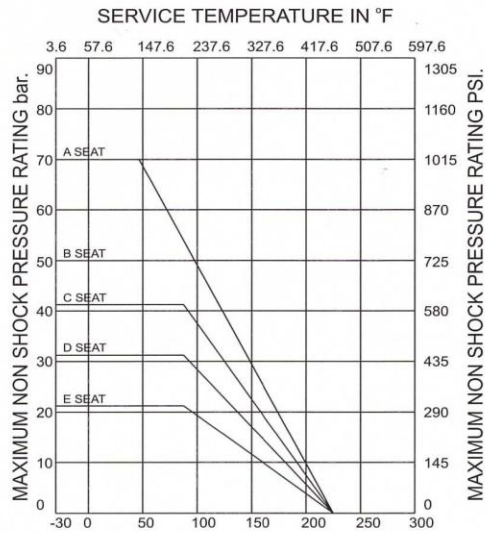

Note : Values for regular port valves. For full port consider next smaller size.

Seat Symbol	Nominal Valve Size	Seat Symbol	Nominal Valve Size
A	8 to 25 RP	D	200 & 250 RP
B	32 to 80 RP		
C	100 & 150 RP	E	300 RP

PTFE seats.

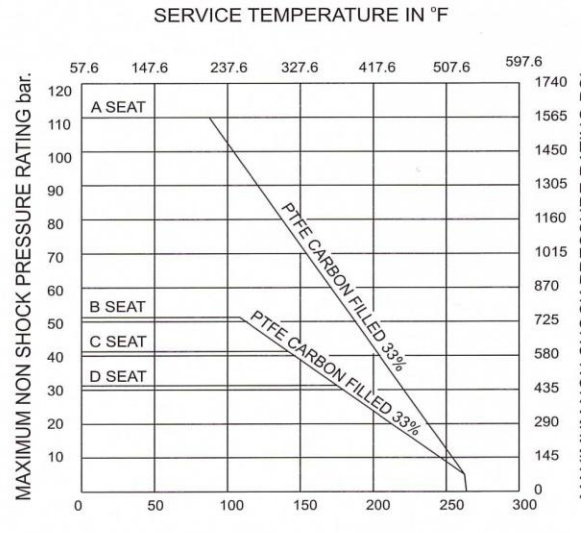

Seat Symbol	Nominal Valve Size	Seat Symbol	Nominal Valve Size
A	8 to 50	D	200 to 300
B	65 to 100		
C	150	E	---

CFT seats.

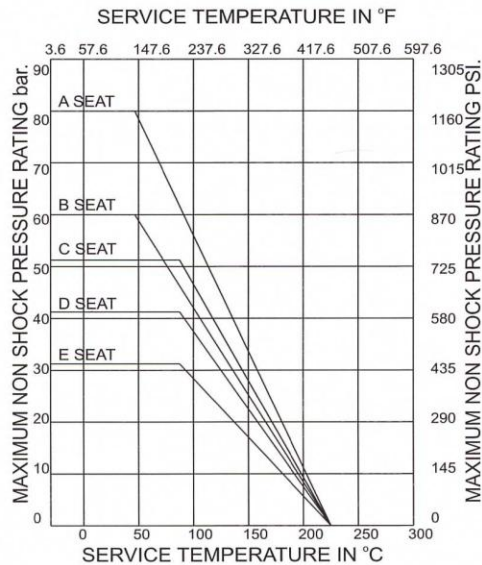

Note : Values for regular Port valves. For full port consider next smaller size.

Seat Symbol	Nominal Valve Size	Seat Symbol	Nominal Valve Size
A	8 to 25 RP	D	200 & 250 RP
B	30 to 80 RP		
C	100 & 150 RP	E	300 RP

25% GFT seats.