



**IVTL**

**General Purpose Rubber Lined Butterfly Valve With Lugged Body**



Yet another real workhorse from the IV stables, IVTL model Butterfly valve incorporates the optimum design features to provide long trouble free service in the field. This general purpose soft seated Butterfly valve has a fully rubber lined single piece body with a centric disc construction and is available in wafer lugged style body pattern to ensure precise location in pipeline.

The body liner which also functions as the soft seat, come either in a replaceable version or an integrally moulded (bonded) version and offers 100 % bi-directional sealing against vacuum to rated pressures of PN 10 or PN16.

The lugged version with threaded holes can be used as end of line valves or terminal end valves.

**Conformity to codes and standards :**

- General design and manufacturing : API 609 category A/BS 5155/MSS SP-67
- Valve face to face dimensions : Short wafer or Wafer lugged as per ISO 5752 Tab 5 & API 609 category A
- Top flange drilling : ISO 5211 part II
- Valve inspection and testing : API 598
- Flange standard conformity : ANSI 150, DIN PN6/PN10/PN16, JIS 5K /10 K  
BS 10 Tab D & E, IS 6392 NP 0.6/1.0/1.6  
For sizes  $\geq$  650 ANSI B16.47 Class 150 Series A / BS 3293 Class 150 and Series B / API 605

**Technical specifications :**

- 1. Valve type : Centric Disc Design Butterfly valve with a single piece Rubber lined body
- 2. Body type : Wafer lugged (IVTL)
- 3. Seat type : Replaceable for sizes 50 NB to 600 NB  $\leq$  PN 10 rating.  
Bonded seat for sizes 40 to 1200 NB for all ratings.
- 4. End connection : Wafer lugged
- 5. Size range : 40 NB to 1200 NB
- 6. Pressure rating : 40 NB to 600 NB-PN 16 (max).  
650 NB to 1200 NB-PN 10 (max).
- 7. Operating temperature range : -25 C to 200 C (depending on MOC)
- 8. Seat leakage : Tight shut off
- 9. Operation : Handlever for sizes from 40 NB to 250 NB  
Worm gear boxes for sizes from 40 NB to 1200 NB  
Pneumatic / Electric actuator operation-optional
- 10. Standard Material of Construction (MOC)
  - Body : CI / SGI / WCB / CF8 / CF8M
  - Disc : SGI / WCB / CF8 / CF8M
  - Seat : EPDM / Viton / Nitrile / Neoprene / Hypalon / Silicon
  - Shaft : AISI 410 / SS 316 SH



DIMENSIONS (in mm.) with Pressed Steel Handlever

Valve size	A	B	C	D	E	F	WT.(kg)
40	40	33	68	103	150	195	5.0
50	50	43	73	113	160	195	5.5
65	65	46	80	121	170	195	6.0
80	80	46	88	128	175	195	7.5
100	100	52	104	146	195	250	10.5
125	125	56	116	158	205	250	13.5
150	150	56	138	174	230	300	15.0

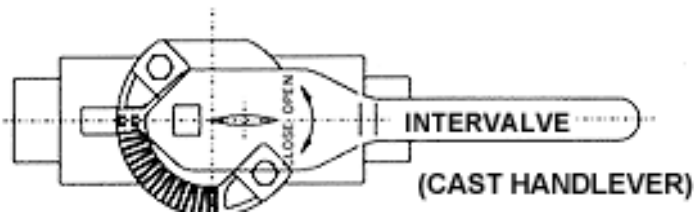

DIMENSIONS (in mm.) with Cast Handlever

Valve size	A	B	C	D	E	F	WT.(kg)
200	200	60	163	198	255	500	18.0
* 250	250	68	203	245	300	500	29.0

\* Valve Rating up to PN6 only.

DIMENSIONS (in mm.) for PN10 & PN16 with Worm Gear

Valve size	A	B	C	D	E	F	G	H	WT(kg)
40	40	33	68	103	230	195	175	127	9.5
50	50	43	73	113	240	195	175	127	11.0
65	65	46	80	121	248	195	175	127	11.5
80	80	46	88	128	255	195	175	127	13.0
100	100	52	104	146	273	195	175	127	16.0
125	125	56	116	158	285	195	175	127	19.0
150	150	56	138	174	340	242	250	182	22.5
200	200	60	163	198	365	242	250	182	25.5
250	250	68	203	245	410	242	250	182	36.5
300	300	78	228	270	486	285	350	252	52.0
350	336	78	265	312	528	285	350	252	62.0
400	386	102	305	360	705	320	600	388	93.5

DIMENSIONS (in mm.) for PN10 with Worm Gear

Valve size	A	B	C	D	E	F	G	H	WT(kg)
450	436	114	330	390	735	320	600	388	108.5
500	486	127	355	410	755	320	600	388	158.5
600	586	154	435	490	810	395	500	445	242.0

DIMENSIONS (in mm.) for PN16 with Worm Gear

Valve size	A	B	C	D	E	F	G	H	WT(kg)
450	436	114	330	390	765	320	600	432	137.0
500	486	127	355	410	730	395	500	445	182.0
600	586	154	435	490	825	420	500	500	296.0

IVTL BUTTERFLY VALVE WITH HANDLEVER

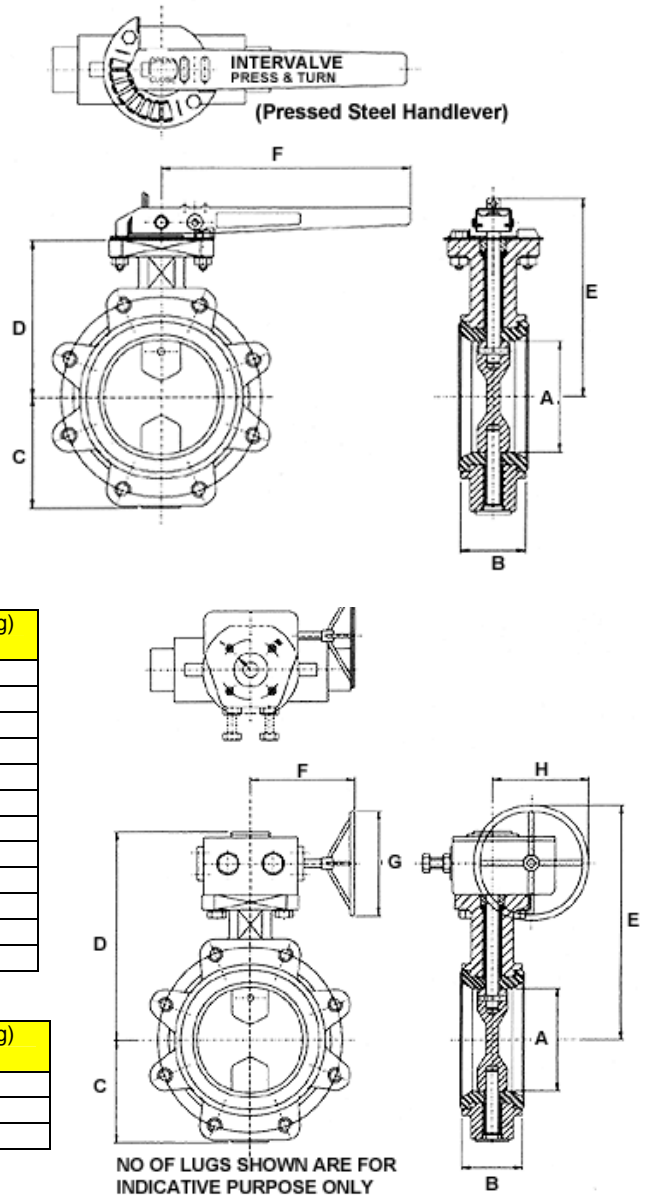

### Key features :

- Unique triple sealing system for shaft sealing, eliminates any fugitive emission or secondary leakage.
- Self lubricated PTFE lined bearings for both drive end and non-drive end shaft ensures minimum bearing friction torque.
- Seat liner extending on to the flange contact faces, eliminates the need for separate flange gaskets during installation.
- Controlled compression of the gasket face to offer optimum sealing & prevent gasket face crushing failure.
- Bi-directional valve with tight shut off sealing capability to hold vacuum to rated pressure in either direction.
- Excellent adaptability for actuated operation through standardised top flange mounting dimensions for actuator fitment.
- Suitability for ON /OFF as well as throttling duties.
- Choice of seat and disc materials to suit media conditions and service requirements.
- The lugged wafer pattern ensures precise self centering of valve between mating flanges.
- Possibility of lower seat rating to obtain reduced operating torque and extended seat life for low operating pressures.